



Town of Guilderland, New York
Department of Water and Wastewater Management

Superintendent: William West
6011 State Farm Road
Guilderland, New York 12084

Phone: (518) 456-6474
Fax: (518) 456-4508

TYPICAL WATER SERVICE INSTALLATION
SPECIFICATIONS AND REGULATIONS



These instructions are being distributed to allow residents to plan their installations. Please note that before committing one's self for hookup work, please verify with this office that service is available to your location.

THIS HANDOUT PACKAGE CONTAINS THE FOLLOWING INFORMATION **PAGE**

PERMITS / RATE SCHEDULE	2
SERVICE LINE SPECIFICATIONS (OUTSIDE)	3
Service Lines	3
Underground Lawn Sprinkling Systems	3
2011 LAWN SPRINKLING REGULATIONS	5
SERVICE LINE SPECIFICATIONS (INSIDE)	8
DIAGRAMS	9
3/4" SERVICE WATER METER INSTALLATION PLAN	9
1" SERVICE WATER METER INSTALLATION PLAN	10
1-1/2" AND 2" SERVICE WATER METER INSTALLATION PLAN	11

These regulations are for use as a general guide, and do not contain specific information concerning meter pits, specific backflow requirements, etc. The Water Department strongly recommends that specific approval be obtained prior to proceeding with installation.

It is also recommended that before work begins, Dig Safely New York be contacted (1-800-962-7962). This organization marks out locations of nearby underground gas, electric and telephone lines at no charge. If water and/or sewer lines need to be located, call the Department of Water and Wastewater Management.

The following points are herein repeated as emphasis of requirements:

1. Each customer or his or her agent is required to obtain an installation permit, available from the Receiver of Taxes.
2. Each installation must be inspected and approved by an employee of the Water Department.
3. No water service is to be turned on until inspection has been made and then only by authorized employees of the Water Department.

The Guilderland Water Department remains available to discuss any questions you may have concerning your installation. We can be reached at (518) 456-6474.

PERMITS / RATE SCHEDULE

Each consumer or his/her agent will be required to obtain a permit prior to work being performed. Permits can be obtained from the Receiver of Taxes at Town Hall.

The rate schedule is as follows:

	<u>Residential</u>	<u>Commercial</u>
1. Underground Lawn Sprinkler & Inspection Fee	\$ 50.00	\$ 100.00
2. 3/4" Water Connection & Inspection Fee	\$125.00	\$ 150.00
3. 1" Water Connection & Inspection Fee	\$150.00	\$ 175.00
4. 3/4" Water Tap - Water Main located on same side of road	\$ 650.00	\$ 650.00
5. 1" Water Tap - Water Main located on same side of road	\$ 675.00	\$ 675.00
6. 3/4" Water Tap - Water Main located on opposite side of road (push under road required)	\$ 975.00	\$ 975.00
7. 1" Water Tap - Water Main located on opposite side of road (push under road required)	\$ 1000.00	\$ 1000.00
8. Commercial and Subdivision Fees	1-1/2" connection fee 2" connection fee 3" connection fee 4" connection fee 6" connection fee 8" connection fee 10" connection fee 12" connection fee	\$ 150.00 \$ 200.00 \$ 300.00 \$ 400.00 \$ 600.00 \$ 800.00 \$ 1,000.00 \$ 1,200.00
9. Meters	5/8" 1" 1 1/2" 2"	Actual Cost: \$ 215.00 Actual Cost: \$ 320.00 Actual Cost: \$ 525.00 Actual Cost: \$ 735.00

Meters larger than 2 " to be furnished by owner to meet Guilderland Water District Specifications.

If road excavation is required as part of a water tap, that additional cost will be borne by the permittee.

**** WATER TAPS MADE BETWEEN APRIL 15TH AND NOVEMBER 1ST ONLY, WEATHER PERMITTING.**

SERVICE LINE SPECIFICATIONS (OUTSIDE)

Each installation must be inspected at the curb box connection, at the entrance to the house, and at any other joint or break in the line between those two points.

At the time of the service cut over from the individual well supply to the public supply, inspection will be required to verify that there is no interconnection between the two systems.

Service Lines

The property owner shall be responsible for the following installations, which shall be at his/her expense:

- Residences shall install Type K copper tubing with a flanged or compression/or HPDE CC OD piping with SS inserts - 200 PSI tubing for connection service into each house (except where the connection exceeds 100 feet, in which sizing is required). (See attached specs.).
- Business or commercial consumers and/or residences that require a service larger than 1" must verify minimum size requirement to meet and provide adequate service.
- Trench depth shall be a minimum of 60 inches (5 feet) below ground surface until it passes into the foundation wall.
- All lines installed under slab construction shall be continuous without the use of compression, sweat, or flared connections.
- A gate valve or ball valve will be installed inside the wall within 12" of point of entry; 3/4" piping will be used from that valve to the meter connection.
- In the event the meter is located more than five feet from the point of entry, an additional valve will be installed.
- No bleeders or "stop and waste" valves allowed.
- Connections of 3" or larger shall be ductile iron, cement lined Class 52 pipe or better quality equal to the American Water Works Association or Federal Specifications. Pipe shall be of weight suitable for service under a pressure equivalent to at least 350 psi is required.

The Department reserves the right in all cases to stipulate the stipulate the size and type of service laterals to be used.

Underground Lawn Sprinkling Systems

Underground lawn sprinkling systems will be permitted under the following conditions:

- a) Applicant must file a set of plans for approval before permit is issued and installation begins. The plans must include the following:

Name, address and phone number of applicant,

Name, address and phone number of Homeowner,

A detailed plot plan showing the location of timer, backflow preventer, (New York State approved double check valve D.C.V.), brand and model number, automatic rain shutoff, etc.

- b) The automatic rain shutoff must be installed as part of pre-installation.

- c) An electrical timer device must be installed to control usage of the sprinkler system. The timer settings must conform to the rules and regulations for lawn sprinkling during the period starting May 1st and ending September 15th of each year.
- d) An outside shutoff valve shall be installed.
- e) A thermal expansion tank shall be installed on the cold water feed line of the hot water tank, and shall be sized according to Local and State plumbing codes.
- f) The Homeowner is responsible for any damage to said sprinkling system on the Town right of way.
- g) The Water Department shall inspect the underground lawn sprinkling system before the system is placed into operation.
- h) The cost of the permit is no less than \$50.00 for residential services and \$ 100.00 for commercial services.

1" - 2" HDPE SERVICE TUBING SPECS

SPECIFICATIONS:

PE 3408 Resin listed in PPI TR4
NSF Standard 61
AWWA C9901
ASTM D 2737
Cell Classification per ASTM D 3350 = 345464E

PRESSURE RATINGS:

All pressure ratings are a maximum PSI @ 73.4°F
If temperatures exceed 80°F, contact Charter Plastic for a working pressure derating.

INSTALLATION:

All Charter PE 3408 CTS Tubing can be direct buried, plowed or pulled. This pipe is not designed for in-house or hot water applications. Buried pipe must be supported by embedment material like sand or gravel. Refer to ASTM D2774 as well as all local, state or federal guidelines. A tracer wire must be attached at both ends of run.

JOINING:

Charter Plastics CTS Tubing is made to ASTM D2737 and AWWA C901 Standards. It can be joined with heat fusion, or mechanical fittings designed for CTS Tubing.

Testing:

All pipe should be hydrostatically tested after installation, not to exceed 150% of the pipes working pressure. Pneumatic testing is prohibited.

WATER SERVICE TUBING

Pressure Rated HDPE
BLACK TUBING with Three Evenly Spaced BLUE STRIPES

Designed for transporting potable water

Water Service

	Size	O.D.	Minimum Wall	Weight Per 100'
200 PSI DR - 9	3/4"	.875	.097	10.3
	1"	1.125	.125	16.8
	1-1/4"	1.375	.153	24.9
	1-1/2"	1.625	.181	34.9
	2"	2.125	.236	59.7

Water Service Tubing - Black with Blue Stripes
Specifically designed for water service applications. The three evenly spaced blue stripes readily identify that the pipe is transporting potable water.

2011 Lawn Sprinkling Regulations

6.8 In order to maintain sufficient water supply and pressure at all times for fire protection and household use, from May 1st through September 15th lawn sprinkling, garden sprinkling and other use of public water supply shall be restricted to the following days and times:

A. Automatic Lawn Sprinkler Systems

1. All dwellings, buildings, structures, lots, pieces or parcels of land connected to the public water supply, with even numbered addresses, and with automatic lawn sprinkler systems serviced by the municipal supply, may use the public water supply for outside lawn & garden sprinkling on even numbered calendar days 1:00 A.M. to 4:00 A.M., regardless of the nature of use of premises.
2. All dwellings, buildings, structures, lots, pieces or parcels of land connected to the public water supply, with odd numbered addresses, and with automatic sprinkling systems serviced by the municipal water supply, may use the public water supply for outside lawn & garden sprinkling on odd numbered calendar days 1:00 A.M. to 4:00 A.M. regardless of the nature of use of premises.
3. All dwellings, buildings, structures, lots, pieces or parcels of land connected to the public water supply, with automatic lawn & garden sprinkling systems serviced by the municipal supply, shall not be permitted to use manually placed and/or handheld lawn sprinklers outside of the times specified in (1.) and (2.) of this subparagraph.

B. Manually Placed Lawn Sprinklers or Handheld Watering

1. All dwellings, buildings, structures, lots, pieces or parcels of land connected to the public water supply, with even numbered street addresses, and without automatic lawn sprinkling systems serviced by the municipal supply, may use the public water supply for outside lawn & garden sprinkling on even numbered calendar days 6:30a.m. to 8:00a.m. and 6:30pm to 8:00pm regardless of the nature of use of the premises.
2. All dwellings, buildings, structures, lots, pieces or parcels of land connected to the public water supply, with odd numbered street addresses, and without automatic lawn sprinkler systems serviced by the municipal supply, may use the public water supply for outside lawn & garden sprinkling on odd numbered calendar days 6:30a.m. to 8:00a.m. and 6:30pm to 8:00pm regardless of the nature of use of premises.

C. The restrictions contained in subparagraphs (A) and (B) above shall not apply to hand sprinkling of outdoor gardens used for the growing of non-commercial foodstuffs and flower gardens.

D. In the event of a fire or other water emergency, the Supervisor, upon the recommendations of the Superintendent of the Department of Water and Wastewater Management, may modify or suspend any or all of the regulations relating to sprinkling for the duration of the emergency. The Department of Water and Wastewater management shall notify the public by publication or other appropriate manner of any modification or suspension of sprinkling as a result of such emergency.

- E. Upon application of any person, the Supervisor, or his/her designee, may vary or modify the restrictions contained herein upon such terms and conditions as he/she deems appropriate. There shall be no appeal from the decision of the Supervisor on an application made under this subparagraph.

- F. Nothing contained herein shall restrict the use of private wells for outside watering purposes, provided that a sign stating PRIVATE WELL must be displayed on the dwelling readable from the right-of-way. All private wells' water faucets must be permanently labeled. No interconnection of the private well with the public water system shall be permitted.

- G. No person shall fill a swimming pool from the public water supply at any time without the approval of the Superintendent of the Department of Water and Wastewater Management. The Superintendent shall specify the quantity, time and method for filling of swimming pools. Any person who violates this subsection shall be guilty of a violation and shall be punishable by a fine of not less than \$50.00 for the first offense, and not less than \$100.00 for any second or subsequent offense committed within the same calendar year.

SERVICE LINE SPECIFICATIONS (INSIDE)

All water meters will be purchased from the Department of Water and Wastewater Management Except as set forth hereafter. All meters will be purchased at the owner's expense. The Water District will be responsible for installation, maintenance and testing of said meters; all water meters will become Water District property.

All meters larger than 2 inches will be purchased by the owner directly from a supplier. Said meters shall conform to the Water Department specifications. The customer will retain ownership of said meter and be responsible for installation, maintenance and testing.

Subdivision developers (those developing three or more lots) shall purchase water meters directly from a supplier. Said meters shall conform to the Water Department specifications.

A water meter will be installed as part of the service connection. However, when the cut over first takes place, the water shall flow freely through a filler piece for approximately two weeks before being replaced by the actual meter.

The Water District shall install the meter and electronic radio transmitter. It shall be installed in an area easily accessible for maintenance and reading.

3/4" Meter The filler piece should be 12-1/2" long with 3/4" male threads on each end and installed with a coupling in such a manner as to permit easy removal when replacing it with the meter. (See 3/4" Meter Specification Diagram sheet)

1" Meter The filler piece will be 15-1/2" long with 1" male threads installed in a like manner as the 3/4" filler piece. (See 1" Meter Specification Diagram sheet)

1-1/2" Meter Flanged Meter (See 1-1/2" Meter Specification Diagram sheet)

In slab construction, the developer or owner shall run reader wire from the meter location to the outside reader location prior to sheetrocking the stud wall.

A gate valve or ball valve shall be installed on both sides of the meter. Valves should be threaded. Sweat joints are not permitted. However, if a sweat valve is used, female thread connections must be available for our inspector to pressure check line and for meter installation (3/4" and 1" female threads only).

Installation should be made adjacent to an outside wall and in an upright, horizontal position. In the event an inside installation is not feasible, the meter shall be installed outside the house in a meter pit, properly protected against freezing. (Pit specifications are available at the District office). In the case of freezing, hot water, or external damage, the customer will be liable for the cost of repairs.

Line pressure should normally range between 60 and 100 psi (pounds per square inch) depending on location. A pressure-reducing valve is required if pressure exceeds 100 psi.

DIAGRAMS

3/4" SERVICE WATER METER INSTALLATION PLAN

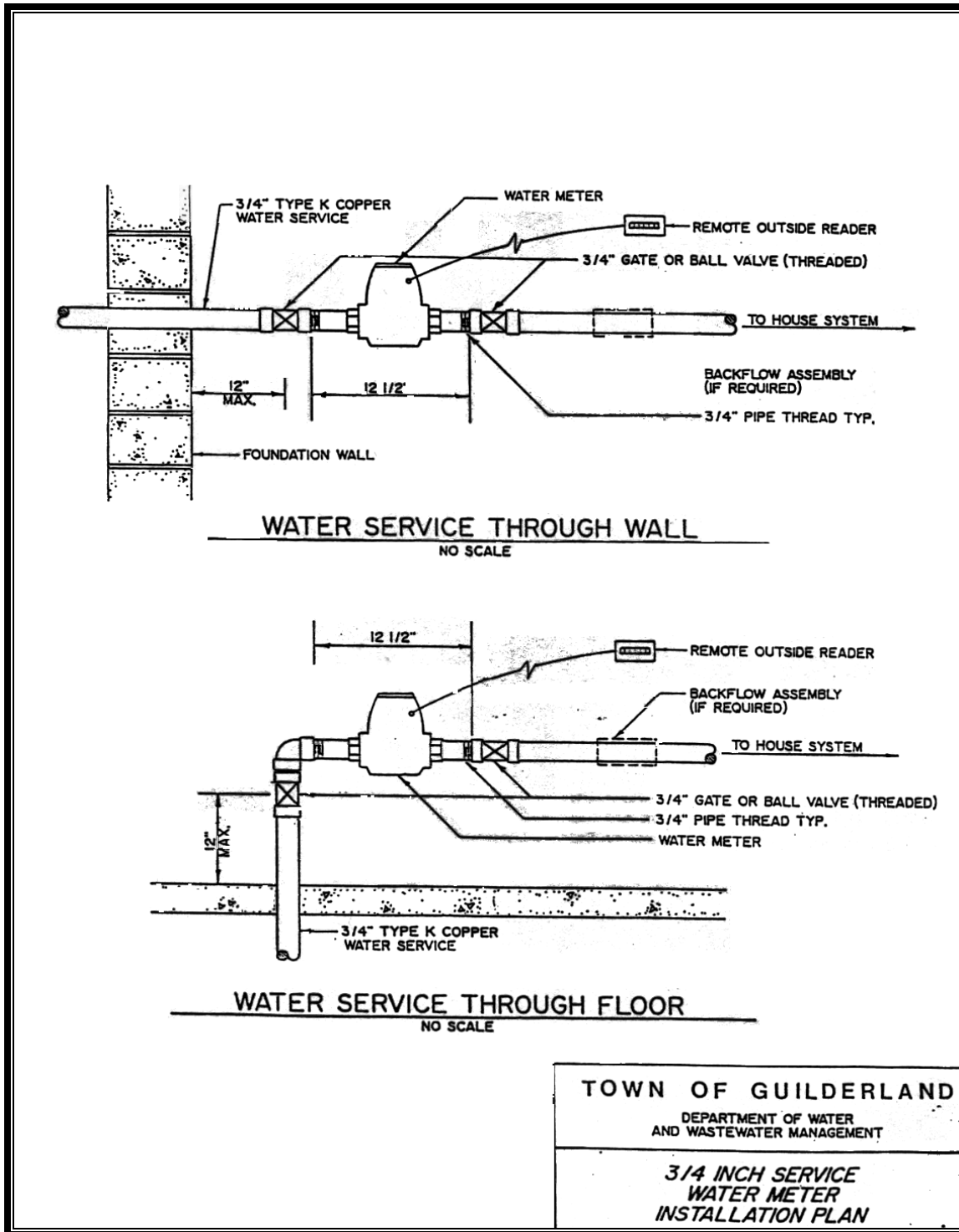

1" SERVICE WATER METER INSTALLATION PLAN

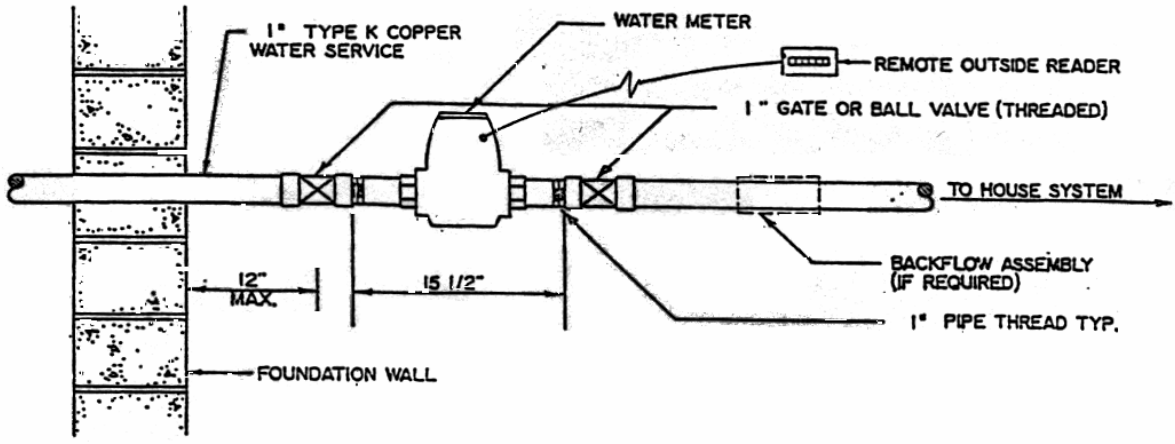

WATER SERVICE THROUGH WALL
NO SCALE

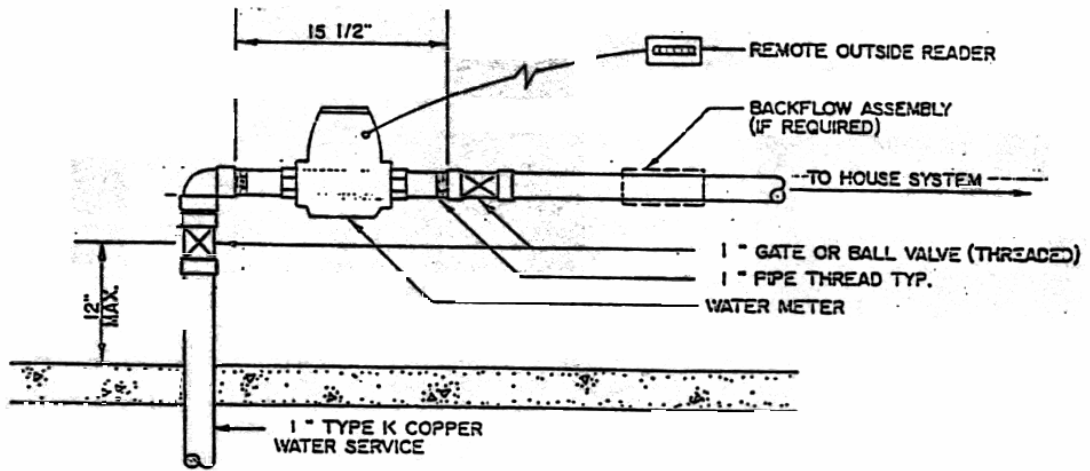

WATER SERVICE THROUGH FLOOR
NO SCALE

<p>TOWN OF GUILDERLAND DEPARTMENT OF WATER AND WASTEWATER MANAGEMENT</p>
<p>1 INCH SERVICE WATER METER INSTALLATION PLAN</p>

1-1/2" AND 2" SERVICE WATER METER INSTALLATION PLAN

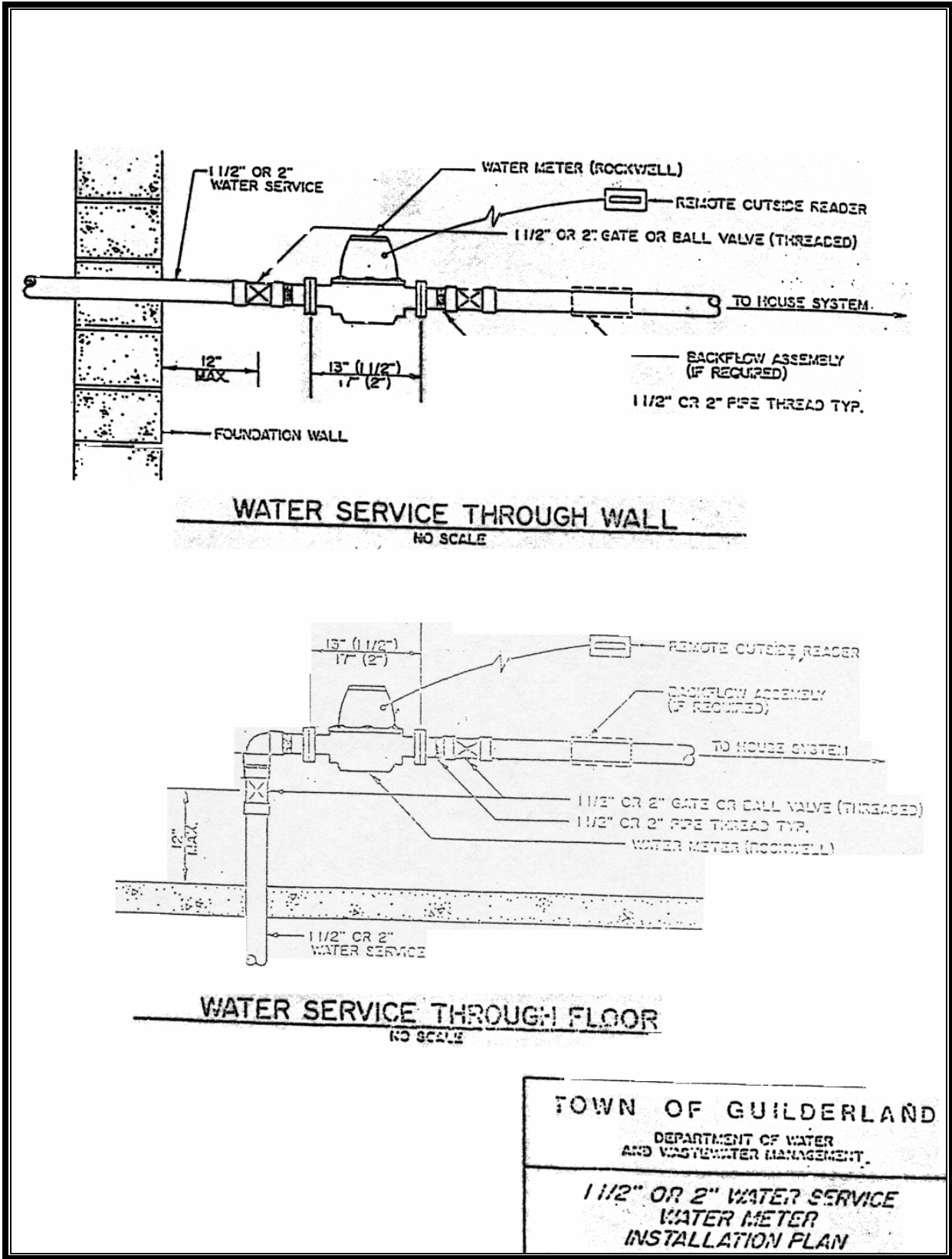

Water Saving Tips

5 THINGS YOU CAN DO TO SAVE WATER IN THE KITCHEN AND LAUNDRY.

1. Use your automatic washing machine only for full loads. Your automatic washer uses 30 to 35 gallons a cycle
2. Use your automatic dishwasher for full loads. Every time you run your dishwasher, you use about 25 gallons of water.
3. If you wash by hand don't leave the water running while you rinse. If you have two sinks, fill one with rinse water. If you have one sink, first gather all your washed dishes in quickly with a spray device or pan of water.
4. Keep a bottle of drinking water in the refrigerator. This puts a stop to the wasteful practice of running tap water to cool it before drinking.
5. Don't let the faucet run while you clean fruit or vegetables. Rinse your vegetables, instead, in a bowl or sink full of clean water.

5 THINGS YOU CAN DO TO SAVE WATER IN THE BATHROOM

1. Check your toilet for leaks. Put a few drops of food coloring in your toilet tank. If, without flushing, the coloring begins to appear in the bowl, you have a leak that may be wasting more than 100 gallons of water a day.
2. Take shorter showers. A typical shower uses five to ten gallons of water a minute. Limit your shower to the time it takes to soap up, wash down and rinse off.
3. Turn off the water brushing teeth. Your use as much as three gallons of water if you leave the water running while brushing your teeth.
4. Install water-saving showerheads or flow restrictors. Your hardware or plumbing supply store stocks inexpensive, easy to install shower heads or flow restrictors that will cut your shower flow to about three gallons a minute instead of five to ten.
5. Check faucets and pipes for leaks. Even a small drip can waste 50 or more gallons of water a day, seven days a week. An inexpensive washer is usually enough to stop them.

5 THINGS YOU CAN DO TO SAVE WATER OUTSIDE.

1. Water you lawn only when it needs it. Watering on a regular schedule doesn't allow for spell or rainfall, which reduce the need for watering. Step on the grass. If it spring back up when you remove your foot, it doesn't need water.
2. Deep soak lawn. When you do water your lawn, water it long enough for water to seep down to the roots where it is needed. A light sprinkling that sits on the surface will simply evaporate and be wasted.
3. Water during the cool parts of the day. Watering during the early morning or evening prevents loss of water due to evaporation and wind.
4. Plant a layer of mulch around tree and plants. Mulch slows the evaporation of moisture.
5. Use a broom to clean driveways, sidewalks and steps. Using a hose wastes hundreds of gallons water.

Check for leaks in pipes, hoses, faucets and couplings. Leaks outside the house can be extremely wasteful, especially when they occur in your main water line or irrigation system. To check for hidden leaks in your pipes, shut off all faucets and taps around the house for 15 minutes. If the water meter reading advances during that time, you have a leak.